

**Supply list for This Is Urban Sketching**  
**Instructor: Wes Douglas, 630-776-2393**

**Something to sketch with:**

- One graphite pencil
- One eraser (white or Pink Pearl)
- One fine liner pen (i.e. Pilot Razor Point, Sakura Micron or Uniball Gel Pen)
- One medium point pen (i.e. Sharpie Ultra Fine Point marker, Flair pen, or 1.0 Micron)

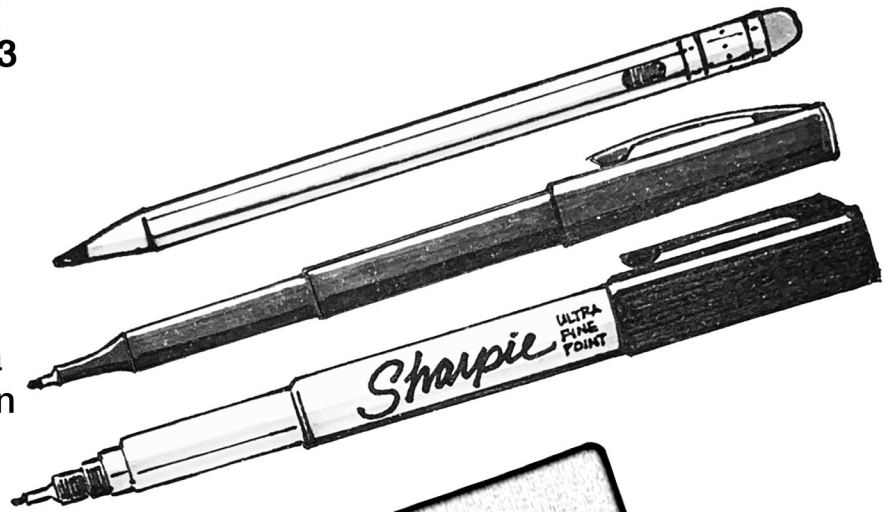

**Something to sketch in:**

Select a sketchbook that is easy to carry and has good quality blank sheets. The sketchbook can be any kind of binding-- I like the spiral bound sketchbooks because it provides a place to clip your pencil or pen so that it always stays with your book.

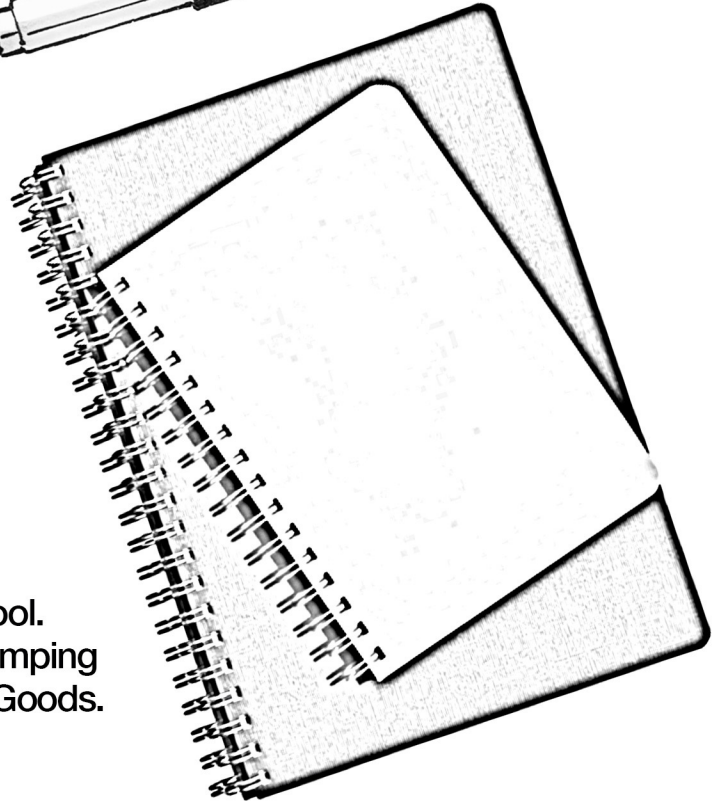

Also, the best size should easily fit inside your backpack, shoulder bag or purse and your drawing preferences.

**Something to sketch on: Drawing Stool**

One small, portable, comfortable and foldable stool. Examples can be found at any store that has camping gear such as Walmart, REI and Dick's Sporting Goods.

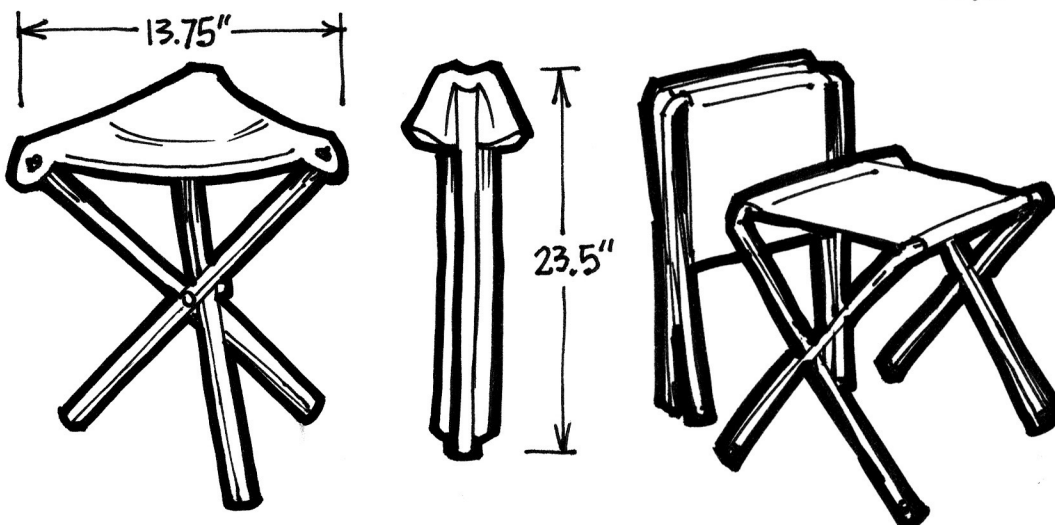

If you have any questions, feel free to email me at [wed317@gmail.com](mailto:wed317@gmail.com)